

HEADLAMP ADJUSTING ASSEMBLIES AND COMPONENTS

	PAGE
HEADLAMP ADJUSTING SCREW ASSEMBLIES	
AMERICAN MOTORS & TRUCKS264
CHRYSLER263
FORD260
GENERAL MOTORS258
HEADLAMP ADJUSTING SCREWS264
HEADLAMP ADJUSTING SPRINGS	
CHRYSLER271
FORD271
GENERAL MOTORS270
HEADLAMP NUTS PIVOTS & SPACERS266
MISCELLANEOUS HEADLAMP PARTS	
BEARING PADS, BUSHINGS & RETAINERS272

HEADLAMP ADJUSTER ASSEMBLIES GENERAL MOTORS

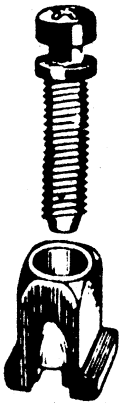

67-3095
HEADLAMP ADJUSTING
NUT & SCREW ASSEMBLY
1-1/2" Screw
G.M. Cars '62/
UNIT PACKAGE 25 KITS

67-3110
HEADLAMP ADJUSTING
NUT & SCREW ASSEMBLY
1" Screw
G.M. Cars '62/
UNIT PACKAGE 25 KITS



68-3249
Replaces: 1231451
HEADLAMP ADJUSTING
NUT & SCREW ASSEMBLY
Firebird '68, G.M. '69 - '72
UNIT PACKAGE 25

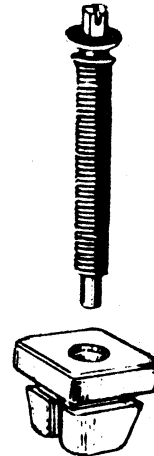

67-3124
HEADLAMP ADJUSTING
NUT & SCREW
G.M. Cars '68
UNIT PACKAGE 25 KITS

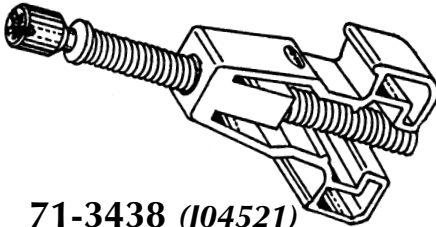

71-3438 (J04521)
Replaces: 1600375
HEADLAMP ADJUSTING
NUT & SCREW
1/4" - 28 x 1 1/2" Screw
Cadillac, Toronado '71/
UNIT PACKAGE 25

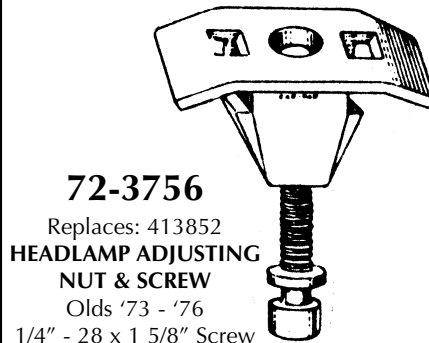

72-3756
Replaces: 413852
HEADLAMP ADJUSTING
NUT & SCREW
Olds '73 - '76
1/4" - 28 x 1 5/8" Screw
"B", "C", & "E" Bodies
UNIT PACKAGE 25



74-4076
Replaces: 354076
HEADLAMP ADJUSTING
NUT & SCREW
1/4" - 28 x 2" Screw
Buick '75/
UNIT PACKAGE 25

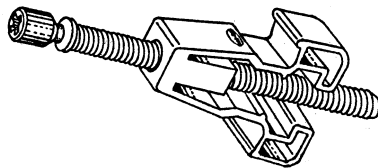

76-4313
Replaces: 1606642, 1618890
HEADLAMP ADJUSTING
NUT & SCREW ASSEMBLY
Pink
1/4" - 28 x 2" Screw
Cadillac '75/
UNIT PACKAGE 25

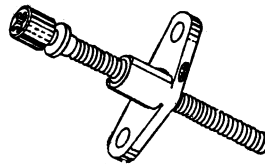

75-4195
Replaces: 417360
HEADLAMP ADJUSTING
NUT & SCREW
Nylon
Olds '75 - '76, Buick '76
UNIT PACKAGE 25

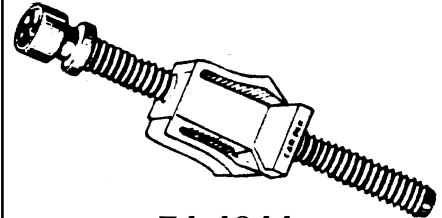

74-4044
Replaces: 343541, 3921446
HEADLAMP ADJUSTING
NUT & SCREW
1/4" - 28 x 2" Screw
Chevrolet '75/
UNIT PACKAGE 25

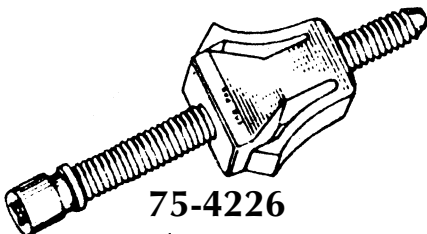

75-4226
Replaces: 364574
HEADLAMP ADJUSTING
NUT & SCREW
White
1/4" - 28 x 2" Screw
Buick '76/
UNIT PACKAGE 25



76-4252
Replaces: 365266
HEADLAMP
NUT & SCREW ASSEMBLY
Green
1/4" - 28 x 2" Screw
Chevrolet Caprice '75/
Full Size Cars '76/
UNIT PACKAGE 25

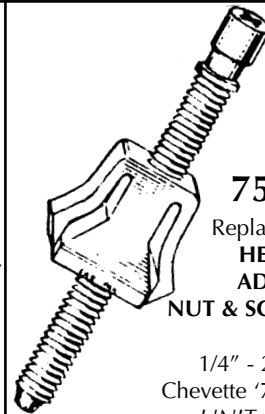

75-4224
Replaces: 343543
HEADLAMP
ADJUSTING
NUT & SCREW ASSEMBLY
White
1/4" - 28 x 2" Screw
Chevette '76/, Mini Van '85/
UNIT PACKAGE 25

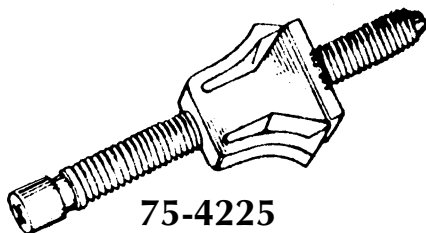

75-4225
Replaces: 343544
**HEADLAMP ADJUSTING
NUT & SCREW ASSEMBLY**
1/4" - 28 x 2" Screw
Chevrolet '76/
"ST" Trucks
UNIT PACKAGE 25

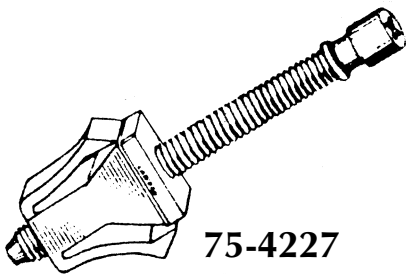

75-4227
Replaces: 364576
**HEADLAMP ADJUSTING
NUT & SCREW ASSEMBLY**
1/4" - 28 x 2" Screw
Buick '76/
UNIT PACKAGE 25

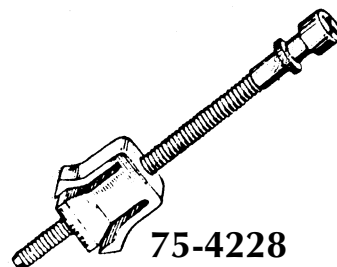

75-4228
Replaces: 362378
**HEADLAMP ADJUSTING
NUT & SCREW ASSEMBLY**
1/4" - 28 x 2 1/4" Screw
Chevrolet '76/
UNIT PACKAGE 25

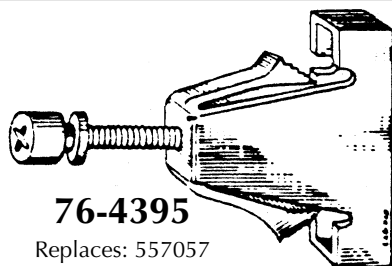

76-4395
Replaces: 557057
**HEADLAMP ADJUSTING
NUT & SCREW ASSEMBLY**
Blue
12 - 28 x 1 3/4" Screw
Pontiac '77/, "A" Body '82/
"P", "C" Body '85/
UNIT PACKAGE 25

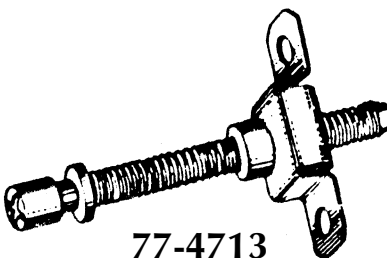

77-4713
Replaces: 1252690
**HEADLAMP ADJUSTING
NUT & SCREW ASSEMBLY**
1/4" - 28 x 1 5/8" Screw
Buick
UNIT PACKAGE 25

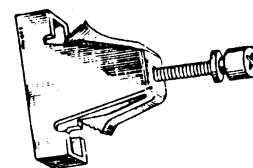

76-4380
Replaces: 556539
**HEADLAMP ADJUSTING
NUT & SCREW ASSEMBLY**
Black
12 - 28 x 1 3/8" Screw
Olds, Buick '77/
UNIT PACKAGE 25

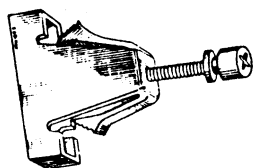

76-4381 (J05162)
Replaces: 556196
**HEADLAMP ADJUSTING
NUT & SCREW ASSEMBLY**
White
12 - 28 x 1 3/8" Screw
Olds '77/
UNIT PACKAGE 25

85-5915

Replaces: 22512857
HEADLAMP ADJUSTER ASSEMBLY
White
Slotted Torx
Screw M5 x 35MM
G.M. "B", "C", "G",
"E" & "X" Bodies '82/
UNIT PACKAGE 10

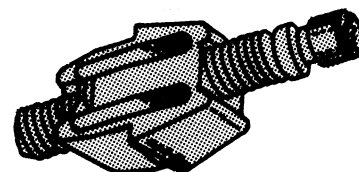

87-6198
Replaces: 16507452
**HEADLAMP ADJUSTING
NUT & SCREW ASSEMBLY**
M5 x 34MM Slotted Torx Screw
Horizontal or Vertical Adjustment
G.M. "J" Bodies '87/
UNIT PACKAGE 10

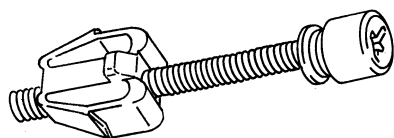

99-7986
Replaces: 15649136
HEADLAMP-ADJUSTING NUT & SCREW
#12-24 X 2" Screw
T15 Torx Recess
G.M. Truck '87/'91
UNIT PACKAGE 5

**"MUST HAVE" BODY SHOP
STARTER ASSORTMENTS ON
PAGES 578 & 549**

FORD



65-1054

**UNIVERSAL HEADLAMP
ADJUSTING NUT & SCREW**
1/4" - 28 x 1 1/2" Screw
Ford Products '61 - '72
UNIT PACKAGE 100

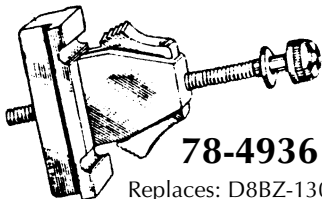

78-4936

Replaces: D8BZ-13032A
**UNIVERSAL HEADLAMP
ADJUSTING NUT & SCREW**
Ford Fairmont '78/
Full Size Ford & Mercury
Mustang & Pinto '79/
Mercury Zephyr '79/
Bobcat '79/
UNIT PACKAGE 25

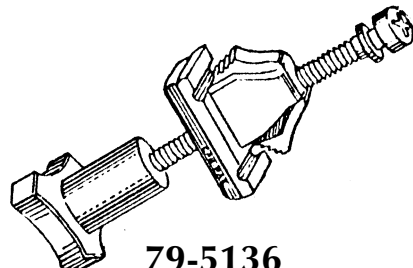

79-5136

Replaces: E0VY-13032A
**HEADLAMP ADJUSTING
NUT & SCREW ASSEMBLY**
Cougar & Lincoln '80/
UNIT PACKAGE 10

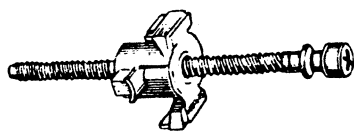

78-4970

Replaces: D9ZZ-13032A
**HEADLAMP ADJUSTING
NUT & SCREW ASSEMBLY**
Ford '79/
UNIT PACKAGE 25

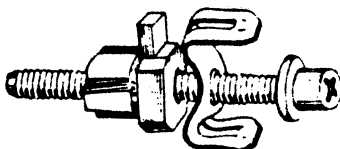

79-4993

Not Supplied By O.E.
**HEADLAMP ADJUSTING
NUT & SCREW ASSEMBLY**
Imported
Ford Fiesta '78/
UNIT PACKAGE 10



ESCORT & LYNX

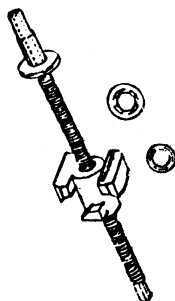

86-6032

Replaces: E6FZ-13032B
**HEADLAMP ADJUSTING
NUT & SCREW ASSEMBLY**
w/'O' Ring & Retainer
For Aerodynamic Headlamp Designs
Horizontal Adjustment
Escort, Lynx '85 - '87
UNIT PACKAGE 5

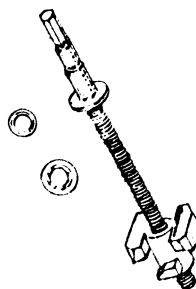

86-6033

Replaces: E6FZ-13032C
**HEADLAMP ADJUSTING
NUT & SCREW ASSEMBLY**
w/'O' Ring & Retainer
For Aerodynamic Headlamp Designs
Vertical Adjustment
Escort, Lynx '85 - '87
UNIT PACKAGE 5

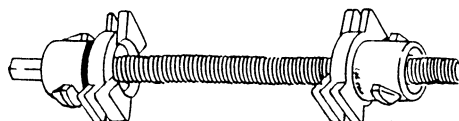

VERTICAL

Brown nut-99-8201. Gray Pivot-99-8203
found on page 249.

90-6782

Replaces: E8FZ-13032C
HORIZONTAL
Screw: M6 x 71.3MM O/L
Clear Chromate Finish
Brown Nut, Gray Pivot
Escort, Lynx '88/
UNIT PACKAGE 5

PROBE

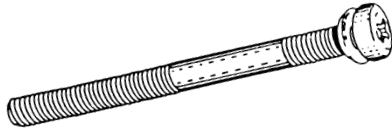

91-6886
 Replaces: E92Z-13032A
**SCREW-HEADLAMP ADJUSTER-
 VERTICAL**
 M5-0.8 x 55MM Phillips Recess
 Use 89-6705 Nut
 Ford Probe '88/
UNIT PACKAGE 15

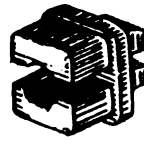

89-6705
 Replaces: E92Z-13A147A
GROMMET NUT-HEADLAMP ADJUSTER
 Plastic
 Ford Probe '89/
UNIT PACKAGE 25

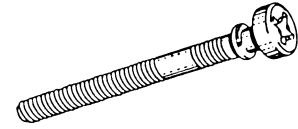

91-6887
 Replaces: E92Z-13032B
**SCREW-HEADLAMP ADJUSTER
 HORIZONTAL**
 M5-0.8 x 40MM Phillips Recess
 Use 89-6705 Nut
 Ford Probe '88/
UNIT PACKAGE 15

TAURUS & SABLE

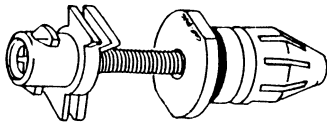

90-6778
 Replaces: E9DZ-13032C
HEADLAMP ADJUSTER PIVOT
 Screw: M6 x 63.4MM O/L
 Black Chromate Finish
 Black Nut, Gray Pivot
 Taurus, Sable '89/
UNIT PACKAGE 5

TEMPO & TOPAZ

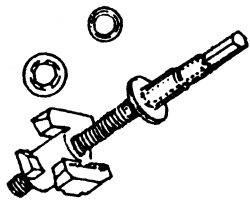

87-6229
 Replaces: E63Z-13032B
**HEADLAMP ADJUSTING
 NUT & SCREW ASSEMBLY**
 w/'O' Ring & Retainer
 For Aerodynamic Headlamp Designs
 Horizontal Adjustment
 Tempo, Topaz '86 - '87
UNIT PACKAGE 10

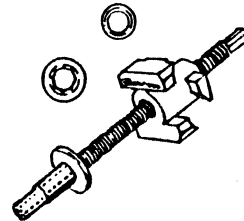

87-6228
 Replaces: E63Z-13032A
**HEADLAMP ADJUSTING
 NUT & SCREW ASSEMBLY**
 w/'O' Ring & Retainer
 For Aerodynamic Headlamp Designs
 Vertical Adjustment
 Tempo, Topaz '86 - '87
UNIT PACKAGE 10

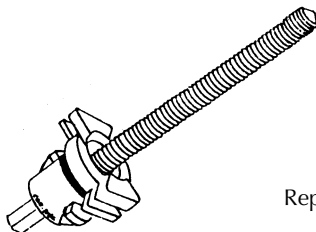

90-6779
 Replaces: E83Z-13032A
 Horizontal
 Black Pivot
 12 - 28 x 76.0MM O/L
 Black Chromate Finish
 Tempo, Topaz '88-'91
UNIT PACKAGE 5

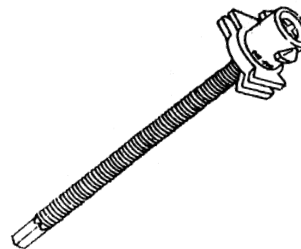

90-6780
 Replaces: E83Z-13032B
 Vertical
 Black Pivot
 12 - 28 x 63.5MM O/L
 Clear Chromate Finish
 Tempo, Topaz '88-'91
UNIT PACKAGE 5

HEADLAMP PARTS

T-BIRD, COUGAR, GRAND MARQUIS, CROWN VICTORIA & CONTINENTAL

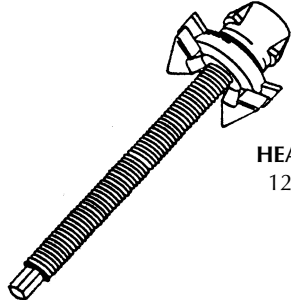

87-6256
 Replaces: E7SZ-13032C
HEADLAMP ADJUSTING ASSEMBLY
 12 - 28 x 2 1/2" Screw Zinc Finish
 Gray Plastic Nut, R.H. Lower;
 L.H. Upper
 T-Bird, Cougar '87 - '88
 Lincoln Continental
 UNIT PACKAGE 5

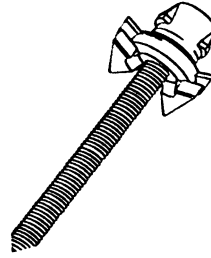

87-6258
 Replaces: E7SZ-13032D
HEADLAMP ADJUSTING ASSEMBLY
 12 - 28 x 63.5MM Screw Zinc Finish
 Gray Plastic Nut, R.H. Upper;
 L.H. Lower
 T-Bird, Cougar '87 - '88
 Lincoln Continental
 UNIT PACKAGE 5

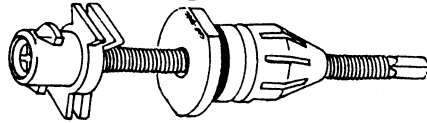

90-6772
 Replaces: E9SZ-13032A
INBOARD END
 Screw: M6 x 71.5MM O/L
 Clear Chromate Finish
 Black Nut, Gray Pivot
 T-Bird '89/
 Crown Victoria '92/
 UNIT PACKAGE 5

90-6773
 Replaces: E9SZ-13032B
CENTER BOTTOM
 Screw: M6 x 66.5MM O/L
 Bronze Chromate Finish
 Black Nut, Gray Pivot
 T-Bird '89/
 Crown Victoria '92/
 UNIT PACKAGE 5

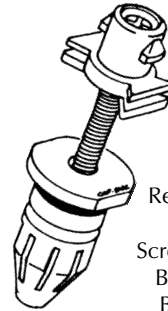

90-6774
 Replaces: E7SZ-13032C
CENTER TOP
 Screw: M6 x 47.5MM O/L
 Black Chromate Finish
 Black Nut, Gray Pivot
 T-Bird '89/
 Crown Victoria '92/
 "F" Trucks '87 - '91
 UNIT PACKAGE 5

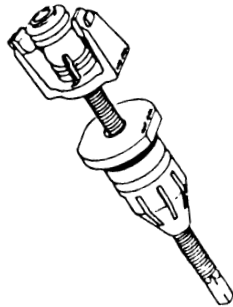

90-6776
 Replaces: E9WY-13032B &
 F2MY-13032B
VERTICAL
 Screw: M6 x 66.5MM O/L
 Bronze Chromate Finish
 Black Nut, White Pivot w/Ret.
 Cougar '89/
 Grand Marquis '92/
 UNIT PACKAGE 5

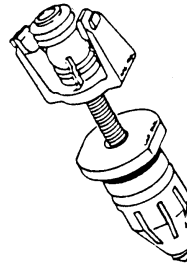

90-6777
 Replaces: E9WY-13032C
PIVOT POINT
 Screw: M6 x 47.5MM O/L
 Black Chromate Finish
 Black Nut, White Pivot w/Ret.
 Cougar '89/
 Grand Marquis '92/
 UNIT PACKAGE 5

FORD TRUCKS

AEROSTAR



92-7090
 Replaces: F29Z-13032A
HEADLAMP ADJUSTER
 Screw: M6 x 65MM O/L
 Screw Torx Drive
 Ford Aerostar '92/'97
 UNIT PACKAGE 5

"F" SERIES (PICK-UP) & "U" SERIES (BRONCO)

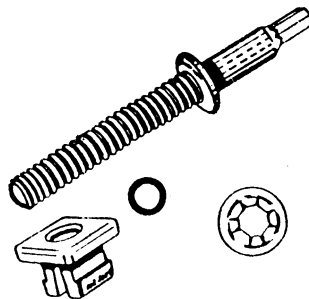

90-6784
 Replaces: E7TZ-13032B
LOWER
 Screw: M6 x 71.5MM O/L
 Black Nut "O" Ring Retainer
 Clear Chromate Finish
 Trucks '87/'91
 UNIT PACKAGE 5

EXPLORER / BRONCO II / RANGER

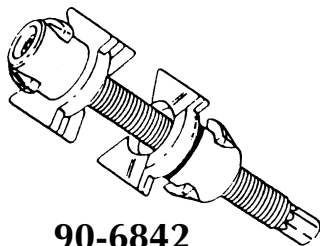

90-6842

Replaces: E9TZ-13032A
HEADLAMP ADJUSTER ASSY.- VERTICAL
 Screw: M6 x 60MM O/L
 Clear Chromate Finish
 Brown Nut, Gray Pivot
 Explorer, Bronco II, Ranger '89-'92
 UNIT PACKAGE 5

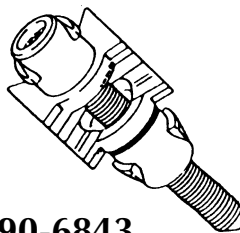

90-6843

Replaces: E9TZ-13032B
HEADLAMP ADJUSTER ASSY.- VERTICAL
 Screw: M6 x 42MM O/L
 Black Chromate Finish
 Brown Nut, Gray Pivot
 Explorer, Bronco II, Ranger '89-'92
 UNIT PACKAGE 5

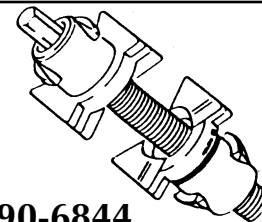

90-6844

Replaces: E9TZ-13032C
HEADLAMP ADJUSTER ASSY.- HORIZONTAL
 Screw: M6 x 50MM O/L
 Bronze Chromate Finish
 Brown Nut, Gray Pivot
 Explorer, Bronco II, Ranger '89-'92
 UNIT PACKAGE 5

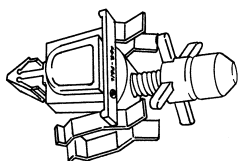

96-7611

Replaces: F37Z-13032-A
Headlamp Adjusting Screw & Nut Assembly
 Pivot Adjustment
 Ford Ranger '93-'97
 UNIT PACKAGE 5

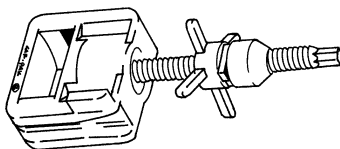

96-7613

Replaces F37Z-13032-C
Headlamp Adjusting Screw & Nut Assembly
 Vertical Adjustment
 Ford Ranger '93-'97
 UNIT PACKAGE 5

CHRYSLER

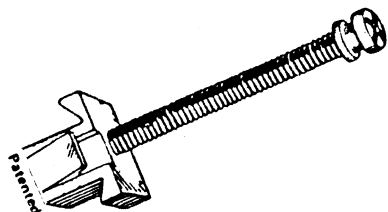

67-3151

HEADLAMP ADJUSTING SCREW & NUT
 Chrysler Products '67 - '70
 UNIT PACKAGE 25

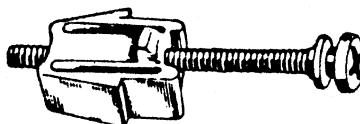

71-3453 (J04327)

Replaces: 3573797
HEADLAMP BEAM ADJUSTING NUT & SCREW ASSEMBLY
 Screw: 12 - 28 x 1 1/2"
 Chrysler Products '71/
 UNIT PACKAGE 25

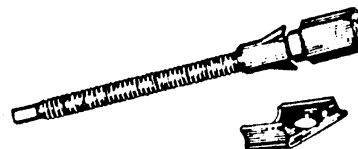

72-3699

HEADLAMP ADJUSTING SCREW & STOP
 Plastic
 Capri '71 - '72
 Chrysler Cricket
 UNIT PACKAGE 25

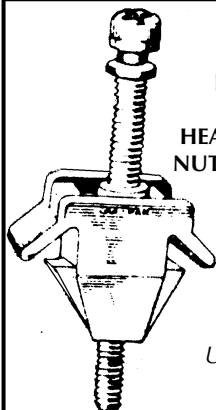

84-5814

Replaces: 433139,
 4334142
HEADLAMP ADJUSTING NUT & SCREW ASSEMBLY
 Slotted Torx Recess Screw
 Screw:
 12 - 28 x 1 1/2"
 White Nut
 Chrysler '78/
 UNIT PACKAGE 25

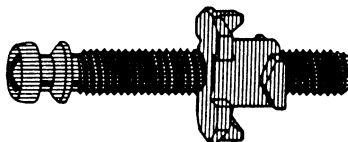

J05197

Replaces: 3691599
ADJUSTING SCREW & NUT- HEADLAMP
 12-28 x 1-1/2"
 Chrysler
 UNIT PACKAGE 25



HEADLAMP PARTS

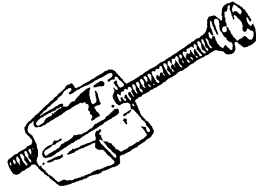

71-3526
 Replaces: 3574085
**HEADLAMP ADJUSTING
 NUT & SCREW**
 Screw: 12 - 28 x 1 1/2"
 Chrysler Products '72/
 (All Except Monaco)
 UNIT PACKAGE 25

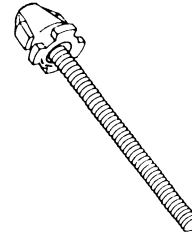

92-7091
 Replaces: 4451998, 4638431
**HEADLAMP ADJUSTER
 ASSEMBLY**
 Screw: 12 - 28 x 3 3/16" O/L Torx Drive
 Chrysler Minivans '91/
 UNIT PACKAGE 5

AMERICAN MOTOR & TRUCK

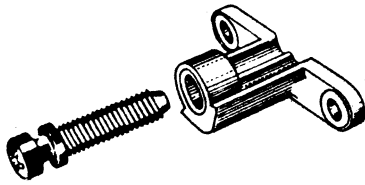

71-3481
 Not Serviced By O.E.
**HEADLAMP ADJUSTING
 NUT & SCREW**
 American Motors Cars '69 - '72
 w/Dual Headlamps
 UNIT PACKAGE 25

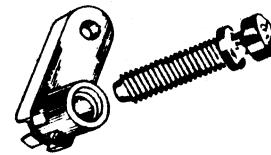

71-3482
 Not Serviced By O.E.
**HEADLAMP ADJUSTING
 NUT & SCREW**
 American Motors Cars '69 - '72
 w/Single Headlight
 UNIT PACKAGE 25

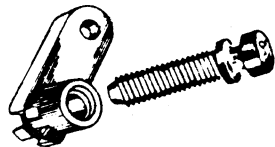

75-4140
 Not Serviced By O.E.
**HEADLAMP ADJUSTING
 NUT & SCREW**
 American Motors Cars '74 - '76
 w/Single Headlight
 UNIT PACKAGE 25

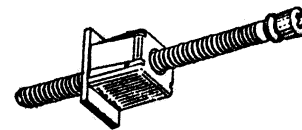

83-5747
 Replaces: 8936000-148 AMC
 176-941117 V.W.
**HEADLAMP ADJUSTING
 NUT & SCREW**
 AMC Encore, Alliance & V.W.
 Products '83/
 UNIT PACKAGE 10

HEADLAMP SCREWS



83-5683
 Replaces: 9437545
SCREW-HEADLAMP ADJUSTING
 12 - 28 x 1 3/8"
 G.M.
 UNIT PACKAGE 25
J05205
 UNIT PACKAGE 50



67-3111
SCREW-HEADLAMP ADJUSTING
 1/4 - 28 x 1"
 G.M. CARS '62 - '72
 UNIT PACKAGE 50



65-1097 (J01973)
SCREW-HEADLAMP ADJUSTING
 1/4 - 28 x 1 1/2"
 G.M. '65 - '67, Ford '65 - '66
 Universal for Other Cars
UNIT PACKAGE 50



68-3240
SCREW-HEADLAMP ADJUSTING
 1/4 - 28 x 1 1/2"
 G.M. Cars '69 - '72
UNIT PACKAGE 25



81-5410 (J05206)
 Replaces: 9437348
SCREW-HEADLAMP ADJUSTING
 12 - 28 x 1 3/4"
 G.M. '76/
UNIT PACKAGE 50



75-4221 (J04549)
 Replaces: 9432645
SCREW-HEADLAMP ADJUSTING
 1/4" - 28 x 2"
 G.M. Cars '75 - '76
UNIT PACKAGE 50



72-3566
 Replaces: 3996200
SCREW-HEADLAMP ADJUSTING
 1/4" - 28 x 2 1/8"
 Camaro '71 - '72
UNIT PACKAGE 50



75-4223
 Replaces: 9436928
SCREW-HEADLAMP ADJUSTING
 1/4" - 28 x 2 1/4"
 G.M. '76
UNIT PACKAGE 50



79-5020
 Replaces: 1612276
STUD-HEADLAMP DOORS
 Cadillac '77/
UNIT PACKAGE 25



67-3123
SCREW-HEADLAMP ADJUSTING
 1/4" - 28 x 1 3/4", Slotted Hex Head
 G.M. Cars '68
UNIT PACKAGE 50



71-3510
SCREW-HEADLAMP ADJUSTING
 Ford Products w/Disappearing
 Headlamps '69 - '71
UNIT PACKAGE 50



67-3121 (J02333)
SCREW-HEADLAMP ADJUSTING
 12 - 28 x 1 1/2"
 Chrysler Products '68 - '72
UNIT PACKAGE 50



J04295
SCREW-HEADLAMP ADJUSTING
 1/4 - 28 x 1-1/4"
 General Purpose
UNIT PACKAGE 50



J05185
SCREW-HEADLAMP ADJUSTING
 1/4 - 28 x 1-3/4"
 General Purpose
UNIT PACKAGE 50



83-5633
 Replaces: 10023094
SCREW-HEADLAMP AIMING
 Up & Down Stop for Disappearing
 Headlight
 G.M. '82
UNIT PACKAGE 25



87-6199
SCREW-HEADLAMP ADJUSTING
 M5 x 34MM Slotted Torx
 Black Phosphate Finish
UNIT PACKAGE 50

HEADLAMP PARTS

HEADLAMP NUTS, PIVOTS & SPACERS

GENERAL MOTORS



80-5153

Replaces: 25501771
NUT-HEADLAMP BEZEL RETAINING
 Olds '80/
UNIT PACKAGE 100

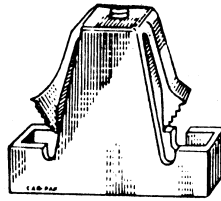

81-5327

NUT-HEADLAMP ADJUSTING
 12 - 28 Screw Size
 Olds '77/
UNIT PACKAGE 50

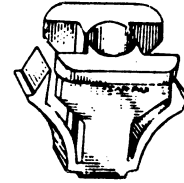

75-4129 (J04571)

Replaces: 343555
NUT-HEADLAMP ADJUSTING
 Chevrolet Passenger '75/
 Chevelle
UNIT PACKAGE 50

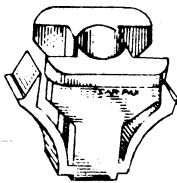

78-4808 (J05207)

Replaces: 365270
NUT-HEADLAMP ADJUSTING
 Green
 For Use on Fiberglass Panels
 G.M. Cars
UNIT PACKAGE 50

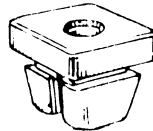

67-3122 (J02287)

Replaces: 3921446
NUT-HEADLAMP ADJUSTING
 G.M. Cars '68/
UNIT PACKAGE 50



NN-3001 (J01745)

NUT-HEADLAMP ADJUSTING
 Chevrolet, Olds, Pontiac
 Buick '62 - '72
UNIT PACKAGE 50



75-4198

Replaces: 1355003, 1370853
NUT-HEADLAMP BEZEL
 Screw: #8
 Buick '64 - '76, Olds '64 - '65
 Cadillac '65/, General Usage
UNIT PACKAGE 100



75-4199

Replaces: 3919773, 347347
NUT-HEADLAMP BEZEL
 No. 8
 Vega '74/, Chevrolet '68/
 Firebird '73/, Cadillac, "M" Vans '85/
UNIT PACKAGE 100



75-4200 (J02648)

NUT-HEADLAMP BEZEL
 G.M. Cars, Also General Purpose
UNIT PACKAGE 100

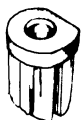

66-1173

Replaces: 5955644
NUT-HEADLAMP DOOR
 Olds (Jet Star) & Starfire '65 - '66
UNIT PACKAGE 100

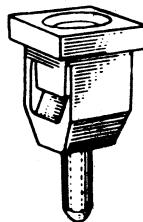

81-5458

NUT-HEADLAMP DOOR SPACER
 1/16" Head Thickness
 Olds
UNIT PACKAGE 50



80-5260

Replaces: 14013246
NUT-HEADLAMP DOORS & HEADER
 Panel
 G.M. '80/
UNIT PACKAGE 50

**72-3606**

Replaces: 3986978
NUT-HEADLAMP DOOR RETAINER
 Chevrolet '71/
 (8 Used Per Car)
UNIT PACKAGE 100

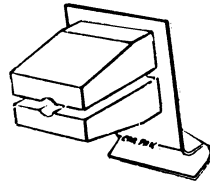
**88-6374**

Replaces: 16503548
GROMMET-NUT & SPRING
 Provides Tension On Headlamp
 Various Models G.M.
UNIT PACKAGE 25

**95-7385**

Replaces: 3783004
GROMMET NUT-HEADLAMP BEZEL
 License Plate
 Plastic
 M4.2 Screw, 7MM Square Hole
 G.M. & General Purpose
UNIT PACKAGE 50

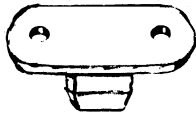
**65-1138**

RETAINER-HEADLAMP RIM TO GRILLE
 Chevrolet '66 - '67
 (4 Used Per Car)
UNIT PACKAGE 100

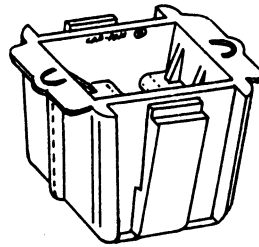
**87-6289**

Replaces: 90181010
RETAINER-HEADLAMP ASSY.
 Plastic
 Pontiac Lemans '88/
UNIT PACKAGE 25

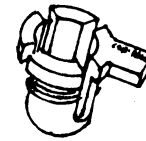
**89-6620**

RETAINER-PIVOT STUD
 HEADLAMP ADJUSTING SCREW
 Plastic
 Buick "H" Body '87/
UNIT PACKAGE 25

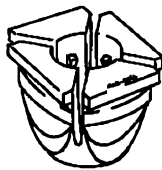
**98-7788**

Replaces: 16506617
SOCKET - HEADLAMP ADJUSTER PIVOT
 Plastic
 Fits 13MM Square Hole
 GM Car & Truck '87-'96
UNIT PACKAGE 25

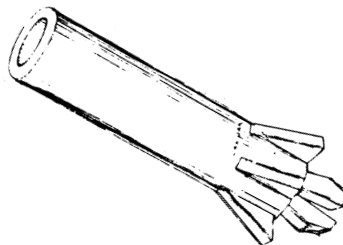
**79-4997**

Replaces: 10004329
SPACER-HEADLAMP
 Imported
 Pontiac '79/
UNIT PACKAGE 50

**J02003**



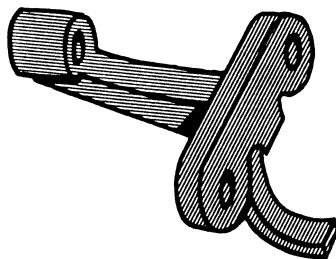

Replaces: 3863669
GROMMET-HEADLAMP SCREW SPACER
 (1-1/4" Long)
 For #8-10 Screw 9/32" Hole
 Chevrolet & General Purpose
UNIT PACKAGE 50

**J01580**

Replaces: 5949838
BRACKET-HEADLAMP
 G.M. Products
UNIT PACKAGE 25

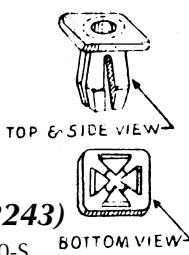
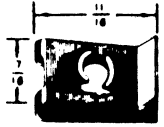
**LOOKING FOR A COST
 RECOVERY SYSTEM?
 GO TO:
www.thelpro.com**

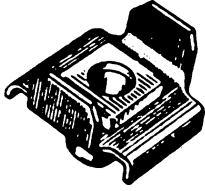
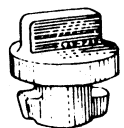
HEADLAMP PARTS

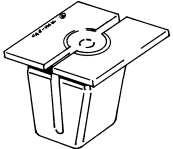
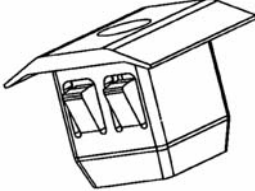
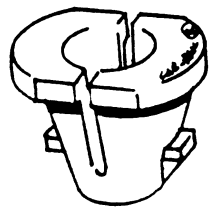
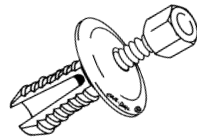
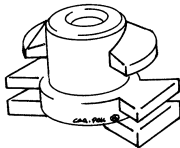
FORD		
 <p>67-3120 (J02243) Replaces: 379830-S NUT-SIDE MIRROR Headlamp Door Attaching Nut Ford & Mercury '67/ Ford, Mercury Comet '66 General Usage <i>UNIT PACKAGE 100</i></p>	 <p>70-3386 Replaces: 355888-S2 HEADLAMP NUT No. 10 Screw Ford Products <i>UNIT PACKAGE 100</i></p>	 <p>66-1189 NUT-HEADLAMP BODY TO HEADLIGHT RIM Nylon, M4.2 Screw Ford Products '66 General Usage <i>UNIT PACKAGE 100</i></p>
 <p>77-4700 Replaces: D3AZ-13021A NUT-HEADLAMP ADJUSTING Ford Light Trucks '73/ General Usage <i>UNIT PACKAGE 25</i></p>	 <p>79-4996 Not Supplied By O.E. HEADLAMP SPACER Imported Fiesta '78/ <i>UNIT PACKAGE 50</i></p>	 <p>98-7849 Replaces: F5RZ-13N129-C GROMMET-HEADLAMP HOUSING TO RAD. GRILLE Plastic Screw: M5, Hole: M8 x 10MM, Flange: 16MM Ford Contour & Mystique '95/ <i>UNIT PACKAGE 25</i></p>
 <p>92-7089 PIVOT SOCKET-HEADLAMP ADJUSTER Plastic Ford Aerostar '92/ <i>UNIT PACKAGE 10</i></p>	 <p>99-8155 Replaces: YS4Z-13N129-AA GROMMET-HEADLAMP MOUNTING AT GRILLE OPENING Plastic Screw: M4.2, Hole: 10x13.5MM, Flange: 20MM sq. Ford Focus 2000/ <i>UNIT PACKAGE 15</i></p>	 <p>99-8810 Replaces: W712160-S300 GROMMET-HEADLAMP Plastic Hole: 15MM Sq, Flange: 22x23.5MM, O/L: 18MM, P.R.: 2.4MM, Screw: M6.3 Ford F150, Expedition & Navigator 2003/ <i>UNIT PACKAGE 15</i></p>
 <p>95-7464 Replaces: FICZ-13A147A SOCKET-HEADLAMP PIVOT Plastic Escort, Tracer '91/ <i>UNIT PACKAGE 25</i></p>	 <p>99-8318 Replaces: W706182-S300 RIVET - SCREW TYPE Headlamp Mounting Plastic Hole: M7.5, Flange: 20MM, Stem Lgth: 13.5MM, Hex: 10MM Ford Focus 2000/ <i>UNIT PACKAGE 25</i></p>	 <p>99-8202* Not supplied by O. E. PIVOT-HEADLAMP ADJUSTING Black Plastic Snaps on to 12-24 adjusting screw Ford Tempo/Topaz '88/ <i>UNIT PACKAGE 25</i></p>

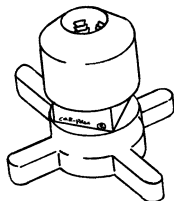

98-7871*

Not Supplied By O.E.
NUT-HEADLAMP HOUSING
 Plastic
 Fits M6 Adjusting Screw
 Ford Mustang '96-'98, Ranger '93/
 Expedition & "F" Series Trucks '97/
 UNIT PACKAGE 25

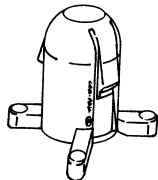

99-8142*

Not Supplied by O.E.
NUT-HEADLAMP ADJUSTING SCREW
 Plastic
 Fits M6 Adjusting Screw
 Adjusting Screw #'s F4ZZ-13032-A &
 F4ZZ-13032-B
 Ford Mustang '94-'98
 UNIT PACKAGE 15

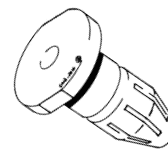

99-8200*

Not supplied by O.E.
NUT-HEADLAMP ADJUSTING
 Black Plastic - use w/89-6651 or 99-8203
 Screw: M6
 Ford Taurus/Sable '89/, T.Bird/Cougar '89/
 Gr. Marquis/Crown Vic. '92/
 'F' Series Truck '87-'91
 UNIT PACKAGE 25

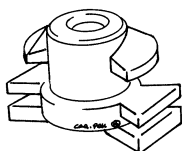

99-8201*

Not supplied by O.E.
NUT-HEADLAMP ADJUSTING
 Brown Plastic - use w/99-8203
 Screw: M6
 Ford Escort/Lynx '88/, Explorer/Bronco II,
 Ranger '89-'92
 UNIT PACKAGE 25

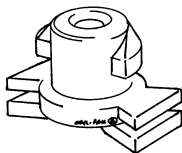

99-8203*

Not supplied by O.E.
PIVOT-HEADLAMP ADJUSTING
 Grey Plastic - use w/99-8200 or 99-8201
 Snaps on to M6 adjusting screw
 Ford Escort/Lynx '88/, Explorer/Bronco II,
 Ranger '89-'92,
 Taurus/Sable, T.Bird/Cougar '89/
 Marquis/Crown Vic. '92/
 'F' Series Truck '87-'91
 UNIT PACKAGE 25

*** Components for headlamp
 adjusters found on pages
 248-251**

CHRYSLER

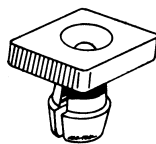

(PLASTIC)

84-5800

Replaces: 6500725
NUT-HEADLAMP BEZEL
 Black No. 10 Screw
 Chrysler "E" Class, Lebaron
 New Yorker, Dodge 400-600 '83/
 UNIT PACKAGE 100



78-4767

Replaces: 6031138
GROMMET-HEADLIGHTS
 Hole: 7x12.7MM, Flange: 12.7x14MM,
 P.R.: 0.8-4.3MM, Screw: #8 (M4.2)
 Chrysler Products
 UNIT PACKAGE 100

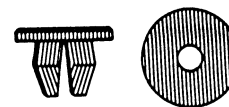

J02000

Replaces: 2524525
GROMMET-HEADLAMP DOOR
 For #8-10 Screw 9/32" Hole
 Chrysler & General Purpose
 UNIT PACKAGE 50

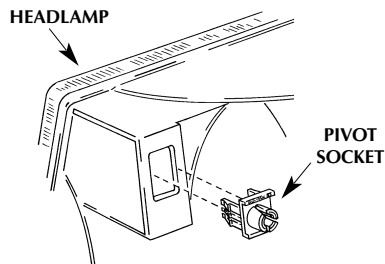

97-7672

PIVOT SOCKET-HEADLAMP ADJUSTER
 Plastic
 Hole: 12MM Square
 Chrysler '91/'94
 UNIT PACKAGE 10

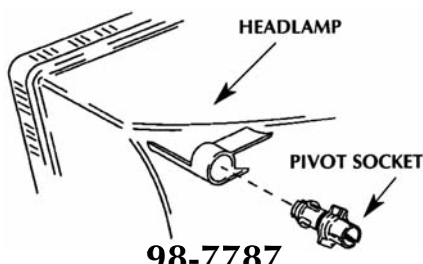

98-7787

Not Supplied By O.E.
PIVOT SOCKET - HEADLAMP ADJUSTER
 Plastic
 Hole: M10
 Chrysler '91 - '94
 UNIT PACKAGE 10

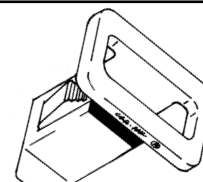

99-8351

NOT SUPPLIED BY O.E.
RETAINER - HEADLAMP
 MOUNTING PANEL
 Plastic
 Hole: 10 X 15MM, Flange: 16 x 22MM,
 O/L: 22MM,, P.R.: 3.3MM
 Jeep Gr. Cherokee '99/
 UNIT PACKAGE 25

HEADLAMP PARTS

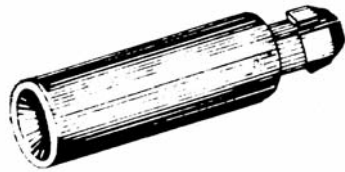

69-3299

Replaces: 6027014
SPACER-HEADLAMP DOOR
 Plastic
 Chrysler Products '68-'69
UNIT PACKAGE 10



J02001

Replaces: 2524526
GROMMET-HEADLAMP SCREW SPACER
 (5/8" Long)
 For #8-10 Screw 9/32" Hole
 Chrysler & General Purpose
UNIT PACKAGE 50

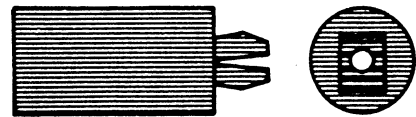

J02002

GROMMET-HEADLAMP SCREW SPACER
 (1" Long)
 For #8-10 Screw 9/32" Hole
 Chrysler & General Purpose
UNIT PACKAGE 50

HEADLAMP SPRINGS

GENERAL MOTORS

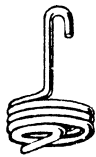

68-3204

Replaces: 3929918
SPRING-HEADLAMP TENSION, R.H.
 Chevy '68
UNIT PACKAGE 25



68-3197 (J02344)

Replaces: 3923948
SPRING-HEADLAMP TENSION
 Chevelle '68 - '76
UNIT PACKAGE 25

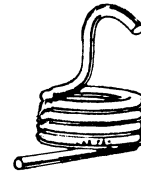

72-3623

Replaces: 478943
SPRING-HEADLAMP ADJUSTING
 Firebird '69/, Lemans '72 - '73
 Chevelle '73
UNIT PACKAGE 25

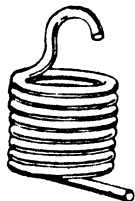

72-3624

Replaces: 9797289
SPRING-HEADLAMP ADJUSTING
 Pontiac '69 - '70
UNIT PACKAGE 25

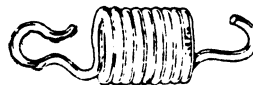

72-3608

Replaces: 1231641
SPRING-HEADLAMP ADJUSTING
 Buick '70 - '72
UNIT PACKAGE 25

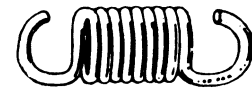

90-6741

Replaces: D3TZ-13031-A
SPRING-HEADLAMP TENSION
 Ford Trucks '73/
UNIT PACKAGE 15

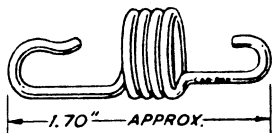

72-3649

Replaces: 1238107
SPRING-HEADLAMP ADJUSTING
 Buick '73
UNIT PACKAGE 25

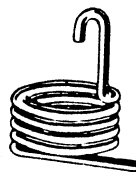

71-3484

Replaces: 3945882
SPRING-HEADLAMP ADJUSTING
 Camaro '70 - '72
 Other G.M. Cars
UNIT PACKAGE 25

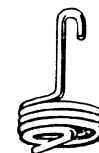

73-3898

Replaces: 342684
SPRING-HEADLAMP TENSION
 Vega, Chevrolet & G.M.C. Truck '74
 Pontiac Astre '75 - '76
UNIT PACKAGE 25

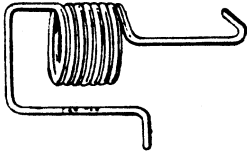

74-4099
 Replaces: 419231
SPRING-HEADLAMP ADJUSTING
 Olds '75, "C", & "E" Bodies RWD
 UNIT PACKAGE 25

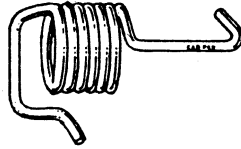

75-4218
 Replaces: 555388
SPRING-HEADLAMP ADJUSTING
 Olds '76/
 "C" Bodies '85/
 UNIT PACKAGE 25

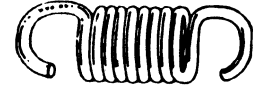

87-6290
 Replaces: 94841758
SPRING-HEADLAMP ADJUSTING
 Chevrolet Nova '85/
 UNIT PACKAGE 25

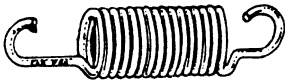

77-4626
 Replaces: 1606118
SPRING-HEADLAMP TENSION
 Cadillac, All Models
 UNIT PACKAGE 25

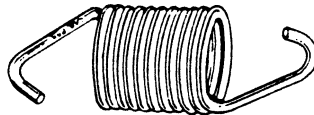

77-4701
 Replaces: 463574
SPRING-HEADLAMP TENSION
 Pontiac '78/
 UNIT PACKAGE 25

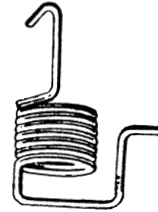

82-5533
 Replaces: 10013753
SPRING-HEADLAMP ADJUSTING
 G.M. "J" Cars '82/
 UNIT PACKAGE 25

FORD

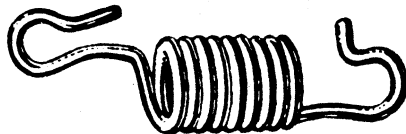

71-3504
 Replaces: D2AZ-13031A
SPRING-HEADLAMP ADJUSTING
 Ford '72
 UNIT PACKAGE 25

CHRYSLER

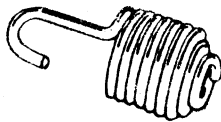

76-4239
 Replaces: 6027292
SPRING-HEADLAMP TENSION
 Closed Back Assemblies
 White, Mack, Freightliner,
 International Harvester
 UNIT PACKAGE 25

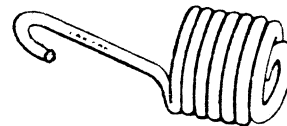

78-4772
 Replaces: 3868549
SPRING-HEADLAMP TENSION
 Plymouth Fury
 Dodge Compacts '78/
 UNIT PACKAGE 25

HEADLAMP PARTS

MISCELLANEOUS HEADLAMP PARTS

GENERAL MOTORS



70-3369

Replaces: 9796903
RETAINER-HEADLAMP
 ADJUSTING SPRING
 Pontiac Grand Prix '69 - '70
 UNIT PACKAGE 50



66-1194

CLIP-HEADLAMP RIM RETAINING
 Plastic
 Chevelle '67
 4 Used Per Car
 UNIT PACKAGE 100

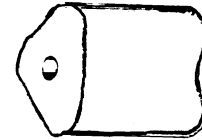

68-3177

Replaces: 3919003
RETAINER-TAIL LAMP
 & BACK-UP LENS
 Nylon
 Chevrolet '68
 UNIT PACKAGE 50

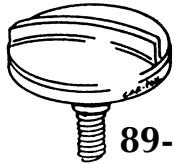
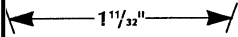

89-6640

Replaces: 14103444
SCREW
 ENCAPSULATED
 (4 Per Car)
 M6-1 x 13MM Stainless Screw
 w/Black Plastic Head
 Retain Headlamp Capsule
 G.M. "L" Bodies & APV Van '87/
 UNIT PACKAGE 5

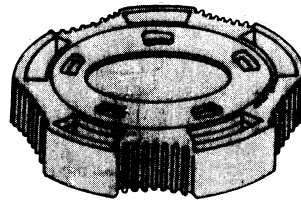

88-6373

Replaces: 16505888
RETAINER
 9004 HEADLAMP
 Composite Headlamp Assembly
 G.M. Cars & 'U' Vans '80-'98
 UNIT PACKAGE 5

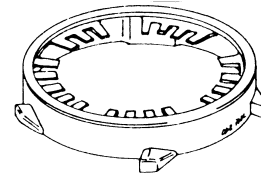

88-6379

Replaces: 16505889
GRIP RETAINER
 9004 COMPOSITE LAMP
 (4 Per Car)
 Cadillac "E", "J", "K" '86
 Olds "N" & "C" Body, Pontiac "H" Body
 UNIT PACKAGE 5

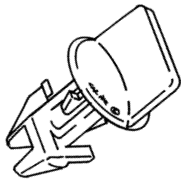

98-7872

Replaces: 25535963, N811772-S
RETAINER-SIGHT SHIELD &
 H/L SHROUD COVER
 Plastic - Twist Lock
 G.M. "C", "H" & "N" Bodies '94 - '96
 Ford Full Size & Lincoln T. Car '98/
 UNIT PACKAGE 15

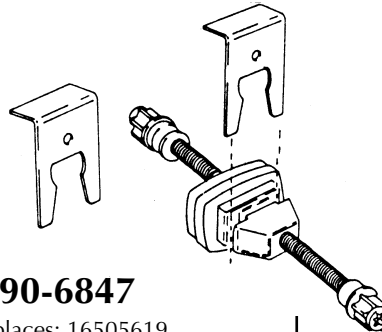

90-6847

Replaces: 16505619
RETAINER-HEADLAMP ADJUSTER
 INBOARD
 Pontiac Bonneville '87/
 UNIT PACKAGE 15

90-6848

Replaces: 16508098
RETAINER-HEADLAMP ADJUSTER
 OUTBOARD
 Pontiac Bonneville '87/
 UNIT PACKAGE 15

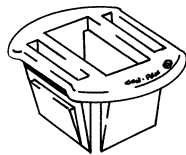

99-8304

Replaces: 10294517
RETAINER-HEADLAMP HOUSING
 Plastic
 Fits 10MM Slot
 G.M. APV 'U' Body Vans '97/
 UNIT PACKAGE 25

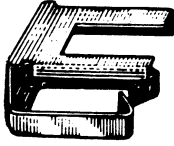

FORD**71-3472**

Replaces: D0VY-13B109C
RETAINER-HEADLAMP
 Ford Products '70 - '71
UNIT PACKAGE 25

**75-4114**

Replaces: D40Z-13B160A
BEARING-HEADLAMP ADJUSTING RING
 Maverick '74, Torino & T-Bird '74 - '75
UNIT PACKAGE 100

**72-3603**

Replaces: C9MY-13B104A
BUSHING
 Disappearing Headlamps
 Ford '69 - '70, Torino '70 - '71
 Mercury '69 - '70
UNIT PACKAGE 100

**72-3636**

Replaces: 384338-S
PIN-HEADLAMP
 Nylon
 Maverick, Comet, Cougar
 and Montego '72
UNIT PACKAGE 100

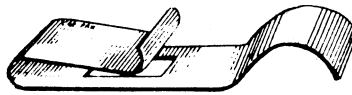
**79-5011**

Replaces: 388133-S100
CLIP
PARKING LAMP ASSEMBLY
 Ford '78/
UNIT PACKAGE 50

**88-6481**

Replaces: E5LY-13A147A
RETAINER-HEADLAMP ADJUSTER
 Escort/Lynx '86, Tempo/Topaz '86/
 Lincoln Mark III '84/'85, Merkur '85/
UNIT PACKAGE 25

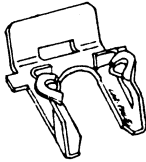
**89-6618**

Replaces: E9DZ-13N129A
RETAINER-HEADLAMP ADJUSTING BAR
 To Header Panel
 Ford Products
 w/Aerodynamic H/L Designs '86/
UNIT PACKAGE 15

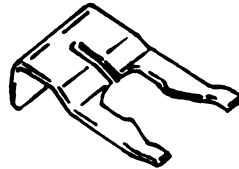
**95-7366**

Replaces: F97Z-13N129A, 5288722AA,
RETAINER-HEADLAMP ADJUSTING BAR
 & SIDE MARKER LAMPS
 To Header Panel
 Ford Ranger '93/, Mustang '94/
 Chrysler Neon 2000/
UNIT PACKAGE 15

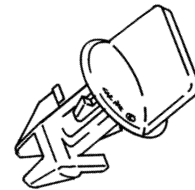
**98-7872**

Replaces: 25535963, N811772-S
RETAINER-SIGHT SHIELD &
H/L SHROUD COVER
 Plastic - Twist Lock
 G.M. "C", "H" & "N" Bodies '94 - '96
 Ford Full Size & Lincoln T. Car '98/
UNIT PACKAGE 15

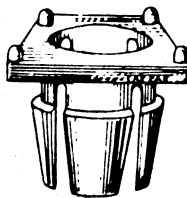
**78-4789**

Replaces: D6AZ-13B019A Outer
 D6AZ-13B020A Inner
BEARING & BUSHING
 Disappearing Headlamp Door
 Ford Products '76/
UNIT PACKAGE 25 SETS

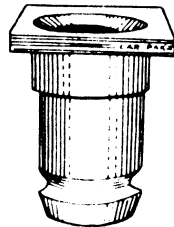
**91-6888**

Replaces: E2SY-13B160A
BEARING-HEADLAMP ADJUSTING RING
 Plastic, 3/8" Tab
 Ford '74 - '76
UNIT PACKAGE 25

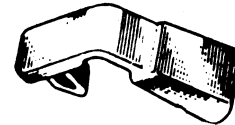

HEADLAMP PARTS

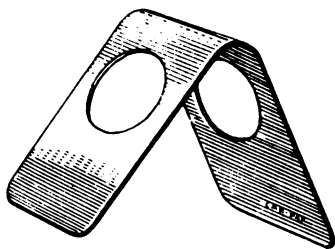
CHRYSLER**78-4966**

Replaces: 6027292
CLIP-CONCEALED HEADLAMPS
 Chrysler Products '77/
UNIT PACKAGE 50

**92-7093**

Replaces: 6502545
RETAINER-HEADLAMP SIGHT SHIELD
 Plastic
 Dodge Daytona '92/
UNIT PACKAGE 25

**96-7525**

Replaces: 55055098
RETAINER-HEADLAMP GASKET
 Black Plastic
 Hole: 3MM, Head: 11MM
 Dodge Ram Full Size Pick Up '94
UNIT PACKAGE 25

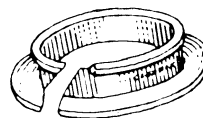
**78-4784**

BUSHING (SPLIT)
 Disappearing Headlamp Doors
 3/4" I.D.
 Chrysler Products
UNIT PACKAGE 50

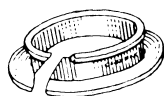
**78-4783**

BUSHING (SPLIT)
 Disappearing Headlamp Doors
 1/2" I.D.
 Chrysler Products
UNIT PACKAGE 50

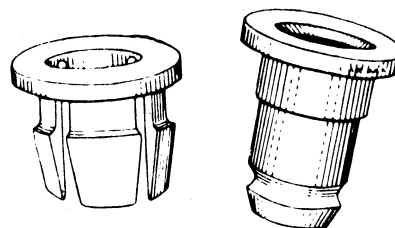
**78-4788**

Replaces: 4016296 Outer
 4016298 Inner
BEARING & BUSHING
 Disappearing Headlamp Doors
 Chrysler Products '77/
UNIT PACKAGE 25 SETS

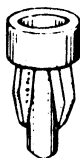
MISCELLANEOUS**73-3824**

NUT-NYLON SPACER
 3/16" Head Height
 Snaps Into 1/4" Hole
 General Purpose
UNIT PACKAGE 100

**73-3825**

NUT-NYLON SPACER
 1/4" Head Height
 Snaps Into 1/4" Hole
 General Purpose
UNIT PACKAGE 100